

## Projekt innowacyjnego modułu budowlanego okno-balkon

Stanisław KOZIOL

ORCID: 0000-0001-9952-2260

Tomasz SAMBORSKI

ORCID: 0000-0001-6914-1678

Andrzej ZBROWSKI

ORCID: 0000-0002-6146-3522

DOI: 10.15199/160.2021.3.2

**Abstract:** The article presents the concept as well as the geometric and calculation model of an innovative window-to-balcony building module that enables a reversible room rearrangement. The module to be mounted in the building structure changes both the net internal area and the exterior (façade) appearance. The window-to-balcony module provides apartment, office, and hotel room users with a flexible solution that allows for a tightly insulated window to be automatically morphed into an open balcony extension, which makes compact interior more spacious and adds external space to it. Depending on the geometric interdependencies of the ventilation system, the window may be tightly or partly sealed, just like typical tilt and turn windows. Moreover, the window can be tilted from the bottom for ventilation purposes or opened fully, in which case it transforms into a balcony.

**Keywords:** building, façade, automation, reconfiguration, arrangement

**Streszczenie:** W artykule przedstawiono koncepcję oraz model geometryczny i obliczeniowy innowacyjnego modułu budowlanego typu okno-balkon, który umożliwia reorganizację pomieszczeń. Moduł montowany w konstrukcji budynku zmienia zarówno wewnętrzną powierzchnię netto, jak i wygląd zewnętrzny (fasadę). Moduł okno-balkon oferuje użytkownikom mieszkań, biur i pokoi hotelowych elastyczne rozwiązanie, które pozwala na automatyczne przekształcenie szczelnie izolowanego okna w otwarte przedłużenie balkonu, co sprawia, że kompaktowe wnętrze staje się bardziej przestronne i dodaje do niego przestrzeń zewnętrzną. W zależności od geometrycznych zależności systemu wentylacyjnego, okno może być szczelne lub częściowo szczelne, tak jak typowe okna uchylno-rozwierane. Ponadto okno może być uchylane od dołu w celu przewietrzenia lub otwierane całkowicie, wówczas przekształca się w balkon.

**Słowa kluczowe:** budynek, elewacja, automatyka, rekonfiguracja, aranżacja

## Introduction

The Łukasiewicz Research Network – Institute for Sustainable Technologies is the third biggest research network in Europe. It delivers attractive, comprehensive and competitive technological solutions, also those requested by and tailored to the needs of companies as part of the “challenge us” campaign, where a company’s request is analysed by a group of 4,500 scientists within no more than 15 business days and an effective solution that is ready to implement is proposed, all at no costs charged to the company. In doing so, Łukasiewicz engages recognised and highly-qualified researchers and unique scientific equipment, which enables the network to meet companies’ needs and expectations. A business owner may choose to contact the network via an on-line form available on <https://lukasiewicz.gov.pl/en/for-business/>, or visit one of its affiliated institutes or branches in more than 50 locations across Poland, and they may be sure that they will always be provided with the same high-quality product or service, no matter which entity they contact. Łukasiewicz’s scientific potential is concentrated in the following research areas: Health, Smart Mobility, Digital Transformation, and Sustainable Economy and Energy. The innovative window-to-balcony solution developed at

the Łukasiewicz Research Network – Institute for Sustainable Technologies and described in this article is an example of a solution proposed in response to a request made in the Health and Sustainable Economy areas.

The structures of modern houses more frequently offer reconfiguration, extension and flexible arrangement possibilities, depending on changing user needs [6, 9]. Modular houses are built from several prefabricated segments that are put together. A window-to-balcony component is one of such modular house segments that additionally allows for a reversible room and façade arrangement [15, 16, 17]. The module to be mounted in the building structure changes both the net internal area and the exterior (façade) appearance.

The window-to-balcony module can be widely used in modern multi-storey buildings in which classic balconies that are a fixed architectural element may not be used for stylistic reasons [4, 10]. The window-to-balcony module provides apartment, office, and hotel room users with a flexible solution that allows for a tightly insulated window to be automatically morphed into an open balcony extension, which makes compact interior more spacious and adds external space to it. Depending on the geometric interdependencies of the ventilation system, the window may be tightly or partly sealed, just like typical

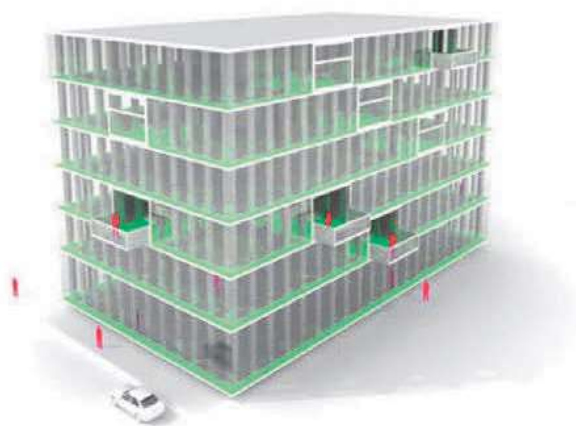

Fig. 1. Residential building with window-to-balcony modules (<https://www.treehugger.com/sustainable-product-design/bloomframe-window-transforms-into-balcony.html>)

tilt and turn windows. Moreover, the window can be tilted from the bottom for ventilation purposes or opened fully, in which case it transforms into a balcony.

### Concept of the mechanism

The authors developed a kinematic diagram of the window-to-balcony structure together with its opening and closing mechanisms. The kinematic diagrams in the most characteristic positions of the module are presented in Fig. 2; in Fig. 2.b the individual components of the window-to-balcony mechanism are marked (1–8).

The complete window-to-balcony module is mounted in the opening in the external building (1). The balcony decking (2) and the balustrade (3) are glazed frames that in the closed position (Fig. 2.a) constitute window frames, and in the open position (Fig. 2.d) become structural elements of the balcony extension. The decking (2), balustrade (3) and balustrade handrail (4) are connected using a joint and they form a rhomboid that – as a result of a changed angle between the sides (Figs. 2.a, 2.b, 2.c, and 2.d) – transforms smoothly from a closed to open position, or vice versa.

To change the rhomboid shape, i.e. to either open or close the window-to-balcony module, a mechanism powered by an electric motor that employs a flexible cable (6) that changes its length and thus modifies the angular position of the decking (2) between its two (vertical and horizontal) positions, is used. The flexible cable is rewound using the passive roller (7) to prevent collision with other components of the mechanism and to ensure that the angle at which the decking (2) is pulled up or down is proper. When the decking (2) is in the horizontal position, the window-to-balcony module plays a role of a balcony extension and it needs to transfer high load of, for example, persons standing on it [11, 12]. Such loads are transferred in particular by the articulated rigid rod (8) of a proper length in the fully extended position (Fig. 2.d). The rod (8) also secures the structure against

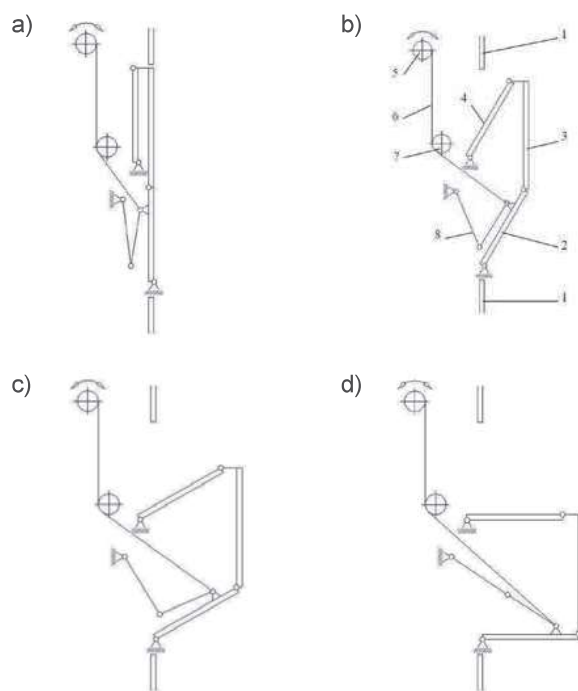

Fig. 2. Kinematic diagram of the window-to-balcony module: a – closed position (window); b – tilted position 1 (30°); c – tilted position 2 (60°); d – open position (balcony); 1 – external wall of a building; 2 – balcony decking; 3 – balustrade; 4 – balustrade handrail; 5 – flexible cable drive system; 6 – flexible cable; 7 – passive roller; 8 – articulated rigid rod

uncontrolled deformation in the event the drive system (5) failure. The mechanism, whose draft is presented in Fig. 3 is composed of two symmetrical systems located at both ends of the structure, the length of which is determined by the transverse dimensions of the decking (2) and the balustrade (3) that decide on the module's net surface. The drive shaft (5) used by the two systems, at the ends of which chain sprockets that cooperate with the cable chains (6) are mounted, ensures synchronous operation of the system in question.

Complying with applicable construction laws [1, 3, 4, 5, 10,], the authors made the following technical assumptions:

Total dimensions (HxWxD)	2,400 x 1,700 x 300 mm
Balcony dimensions (HxWxD)	1,100 x 1,300 x 900 mm
Permitted load	2.5 kN/m <sup>2</sup>

### 3D model

The 3D model of the balcony extension module was developed in accordance with the above-described concept of the opening/closing mechanism and in compliance with applicable construction laws [7]. The model covers the complete window-to-balcony module ready

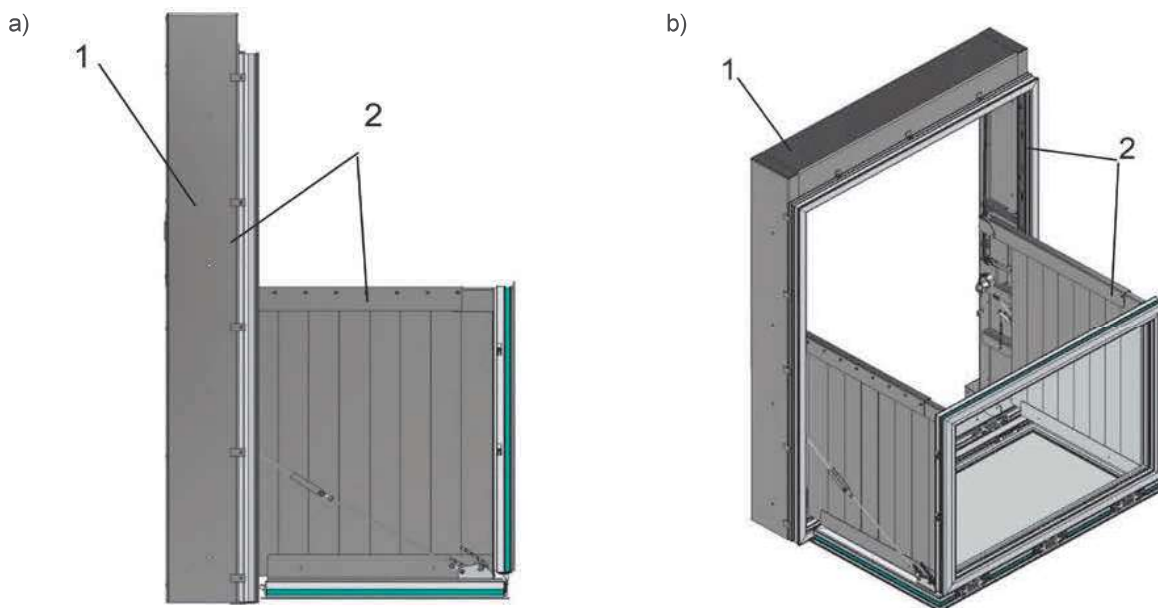

Fig. 3. Complete window-to-balcony module ready to mount in the building wall: a) 2D side view; b) 3D view; 1 – complete case; 2 – window-to-balcony – functional part

to mount in a properly prepared opening in the external building wall.

The complete window-to-balcony module ready to mount in the building wall (Fig. 3) is composed of the following two main units:

- a case mounted in the wall;
- a moveable functional part with a jamb that is mounted in the case and—depending on the position—plays the role of a window or balcony extension.

The case (Fig. 3) is to be installed in the building wall using fasteners fitted in holes with the diameter of 12 mm, and it has the form of a frame welded from bent steel profiles (Fig. 4) in which individual mechanisms and control systems responsible for the operation of the window-to-balcony module are placed.

In the frame there are elements, holes, and threaded holes for the installation of the following mechanisms and systems:

- a moveable functional part with a jamb that plays the role of a window or balcony extension and is mounted using screw fasteners and anchor bolts welded in the frame;
- a chain opening and closing mechanism including an electric drive, gearbox, two synchronous chain gears, and an emergency power supply battery;
- mechanisms supporting the opening of the window-to-balcony module in the initial movement phase;
- collapsible rods transmitting loads in the 'balcony' position;
- proximity sensors identifying characteristic positions of the moveable functional part;
- a control panel with which the user operates the window-to-balcony module; and
- inside frame and mechanism covers.

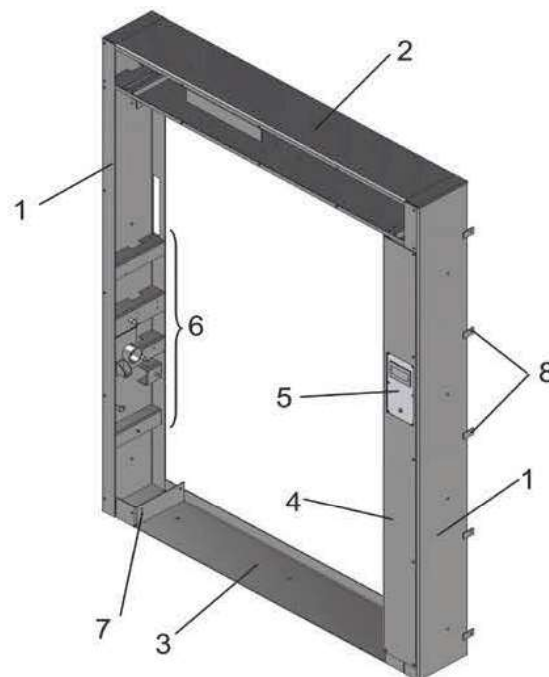

Fig. 4. Frame of the window-to-balcony case welded from bent steel profiles: 1 – vertical profiles (columns); 2 – top profile with a drive system case; 3 – bottom profile; 4 – cover mounted on the case; 5 – control panel; 6 – supports with mechanism assembly elements; 7 – cover mounting bracket; 8 – anchor bolts for the assembly of the window-to-balcony usable part

The moveable functional part of the window-to-balcony module (Fig. 5) is a window structure made of aluminium profiles with good thermal insulation properties (Pon-zio) [2, 13] that is composed of a jamb and two sashes connected with high-load capacity hinges, and equipped with dedicated, collapsible side balustrades. The jamb is mounted on the frame of the window-to-balcony module

case using 17 screw fasteners screwed on to welded anchor bolts (Fig. 4). The sides of the jamb are connected in each corner with special shape fasteners with strength higher than in the case of typical window or door solutions.

The synchronous movement of both sashes is ensured, as assumed during the concept phase, by the top handrails of the side balustrades that constitute one of the rhomboid's sides. The side balustrade (Fig. 5) is composed of a grip mounted to the top window frame, a guide mounted to the bottom window frame, a top panel (handrail) connecting the top edge of the top sash with the case frame, and the balustrade infill made of overlapping segments that, when closed, fold similarly to blind laths or folding fan leaves.

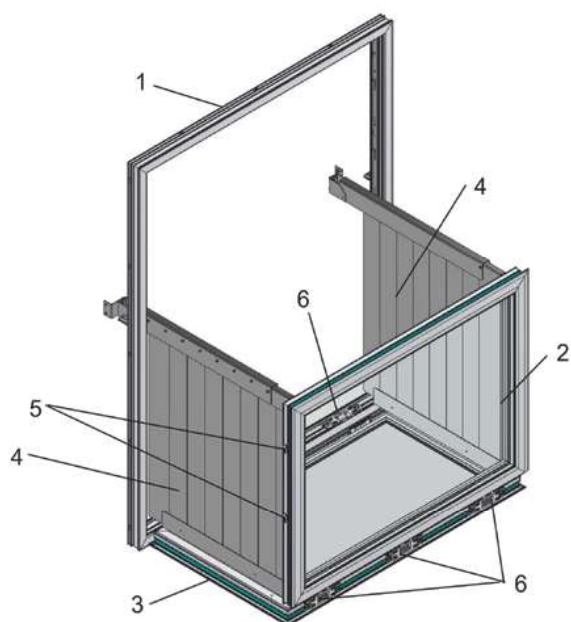

Fig. 5. Moveable functional part of the window-to-balcony module: 1 – jamb made of PONZIO profiles; 2 – top sash playing the role of the front railing; 3 – bottom sash playing the role of the balcony's floor; 4 – side balustrades; 5 – window lock catches; 6 – high-load capacity hinges

The window-to-balcony module is opened and closed by an electric drive system that includes a direct current electric drive, a two-stage worm gearbox and an emergency power supply battery (Fig. 6). The rotational motion is transmitted by a long shaft with chain sprockets located at the ends of the top profile of the window-to-balcony case.

Top chain sprockets put cable chains wrapped around chain sprockets located in the bottom sash into synchronous motion (Fig. 7). The passive end of the cable chain is fixed to the frame of the window-to-balcony case. The drive system lengthens or shortens the cable chain, which results in the opening and closing of the window-to-balcony module respectively.

When fully closed (the 'window' position) the sashes are locked with the use of a locking mechanism

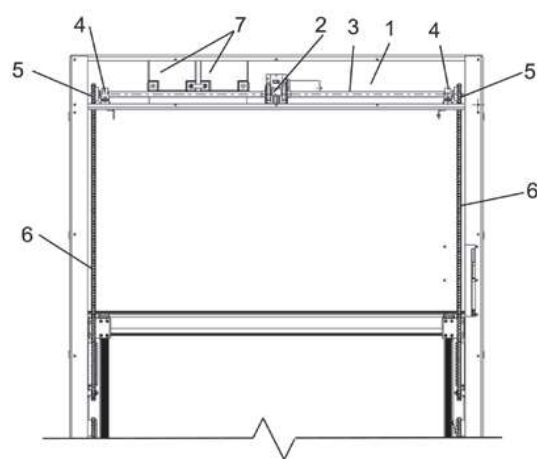

Fig. 6. Drive of the closing/opening mechanism: 1 – top case profile; 2 – gear motor with a direct current electric drive; 3 – drive shaft; 4 – bearing support; 5 – chain sprockets; 6 – cable chains; 7 – emergency power supply batteries

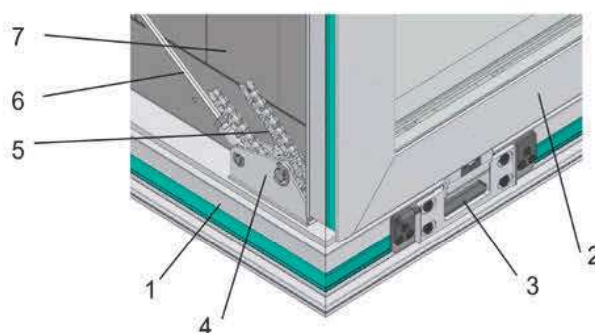

Fig. 7. Cable chain and rod grip in the bottom sash: 1 – bottom sash; 2 – top sash; 3 – hinge; 4 – cable chain and rod grip; 5 – cable chain (fragment); 6 – articulated rigid rod; 7 – balustrade infill

consisting of roller latches located symmetrically at the opposite sides of the jamb, the roller bolts of which move into mortises in strike plates fitted in window frames. The latch is closed automatically by electric actuators fitted in the frame of the case and hid in the mortises in the jamb. When the module is locked in the 'window' position, the load resulting from the wind pressure [8, 9] or pressure difference is transferred onto the locking mechanism; the mechanism also ensures that the window is tightly sealed. In such a position, the tension of the active cable chain can be released.

### Strength calculations

The authors calculated the strength of elements and structural nodes of the window-to-balcony module carrying the heaviest load. In calculations the loads resulting from the weight of the designed structure and the balcony decking load capacity complying with applicable construction laws were used [11, 12]. Mechanism strength calculations [8, 14] were made in Mathcad, and modelled complex element calculations – in Autodesk Inventor Professional, using the MES method [7]. Strength calculations concerned in particular: the latch mechanism

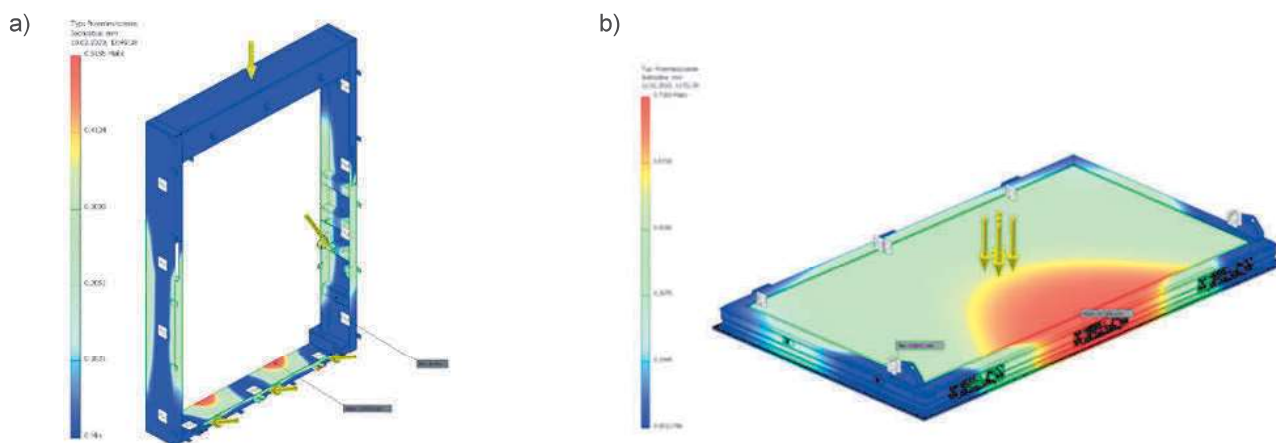

Fig. 8. Shift distribution maps for a) the case frame and b) the floor of the window-to-balcony module under maximum load obtained during the MES analysis

with an articulated rigid rod and catches; hinges; and the opening/closing mechanism with a cable chain. The MES analysis was performed on the frame of the window-to-balcony module case, front and side balustrades, and the balcony floor (decking). Sample maps of the window-to-balcony module case and floor shift distribution under maximum load obtained during the MES analysis are presented in Fig. 8.

## Summary

The developed structural design enables the implementation of a reconfigurable module in modern buildings with changeable net internal area and the façade arrangement. The proposed structure of the module is an alternative to traditional building design in which fixed structural elements are used. The module design includes mechatronic components with automatic diagnostics and safety systems. Future work will focus on the construction of a prototype and verification tests that will enable all required permits and certificates to be issued and the product to be marketed.

## References

- [1] Appendix no. 1 to the Ordinance of the Minister of Infrastructure of 12 April 2002: List of Polish norms referred to in the Ordinance.
- [2] Appendix no. 2 to the Ordinance of the Minister of Infrastructure of 12 April 2002: Thermal insulation requirements and other energy efficiency-related requirements.
- [3] Appendix no. 3 to the Ordinance of the Minister of Infrastructure of 12 April 2002: Terms relating to flammability and fire propagation as used in the Ordinance and corresponding reaction to fire and roof fire resistance classes.
- [4] Construction Law of 7 January 1994 (consolidated text, Journal of Laws of 2019, Item 1186, as amended: Journal of Laws of 2018, Item 2245 and of 2019, Items 1309, 1524, 1696, 1712, 1815, and 2170)
- [5] Construction Products Act of 16 April 2004 (consolidated text, Journal of Laws of 2019, Item 266, as amended: Journal of Laws of 2019, Item 730).
- [6] Dymkowski R. 2015. Okna dachowe - inne niż inne. Fachowy Dekarz & Cieśla. 03.2015. <http://fachowydekarz.pl/okna-dachowe-inne-niz-inne/>
- [7] <http://www.autodesk.pl/products/inventor/features/simulation-visualization>
- [8] Jastrzębski P., Mutermilch J., Orłoś W. 1985. Wytrzymałość materiałów. Warszawa: Arkady.
- [9] Konstantinos-Alketas Oungrinis. 2013. "Implementation of Kinetic Systems in Architecture: A Classification of Techniques and Mechanisms Appropriate for Discreet Building Parts". Conference: International Conference on Adaptation and Movement in Architecture (ICAMA2013), Toronto Canada, Volume: Proceeding of International Conference on Adaptation and Movement in Architecture.
- [10] Ordinance of the Minister of Infrastructure of 12 April 2002 regarding technical conditions to be met by buildings and locations in which they are erected (consolidated text, Journal of Laws of 2019, Item 1065).
- [11] PN-EN 1990 Eurocode: Basis of Structural Design.
- [12] PN-EN 1991 Eurocode 1: Actions on Structures.
- [13] PN-EN ISO 10077-1:2007 Thermal performance of windows, doors and shutters — Calculation of thermal transmittance — Part 1: General.
- [14] Podstawy konstrukcji maszyn. 1995.Vol. 1, ed. M. Dietricha, Kraków: WNT,.
- [15] Rider N. 2017. "Australian first: window-meets-balcony system to be used for Brisbane tower". Architecture & Design 3.
- [16] Rogers S. A.: Bloomframe: Window Morphs Into a Balcony in Seconds. <https://weburbanist.com/2016/01/29/bloomframe-window-morphs-into-a-balcony-in-seconds/>
- [17] Smisek P.: The Window that Transforms into a Balcony. <https://www.theb1m.com/video/bloomframe-the-window-that-transforms-into-a-balcony.02.2018>.

dr inż. Stanisław Koziol – Łukasiewicz Research Network – Institute for Sustainable Technologies,  
ul. K. Pułaskiego 6/10, 26-600 Radom,  
e-mail: stanislaw.koziol@itee.radom.pl

dr inż. Tomasz Samborski – Łukasiewicz Research Network – Institute for Sustainable Technologies,  
ul. K. Pułaskiego 6/10, 26-600 Radom,  
e-mail: tomasz.samborski@itee.radom.pl

dr hab. inż. Andrzej Zbrowski, prof. Ł-ITeE-PIB Łukasiewicz Research Network – Institute for Sustainable Technologies,  
ul. K. Pułaskiego 6/10, 26- 600 Radom,  
e-mail: andrzej.zbrowski@itee.radom.pl